

**Notwithstanding Ordinance
for the installation of a mural and
artwork on Maryland Avenue in
East Price Hill and
Lower Price Hill**

Economic Growth and Zoning Committee
January 5, 2021

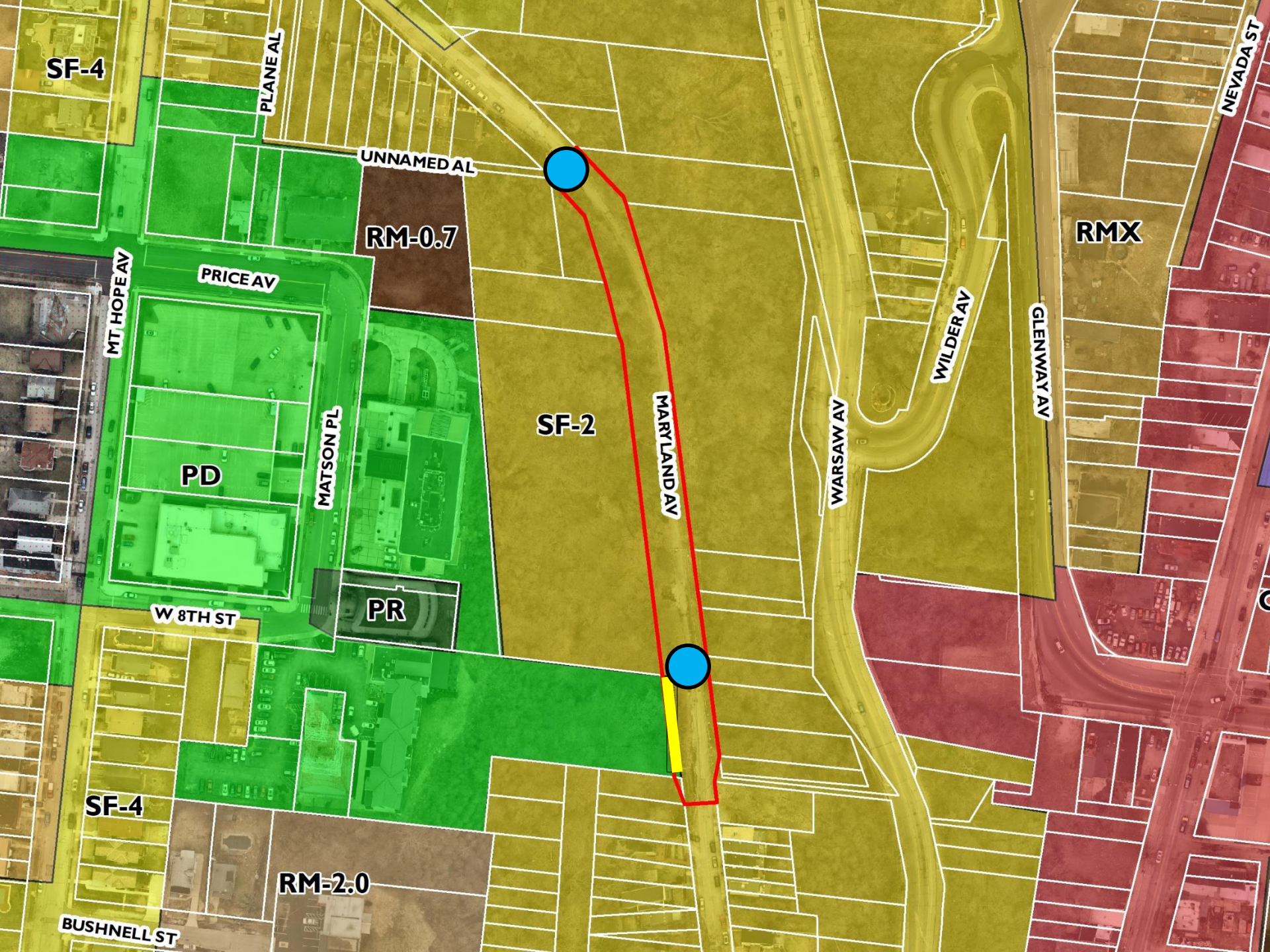

SF-4

PLANEAL

UNNAMED AL

RM-0.7

PRICE AV

MT HOPE AV

MATSON PL

PD

PR

W 8TH ST

SF-2

MARYLAND AV

WARSAW AV

WILDER AV

GLENWAY AV

RMX

NEVADA ST

SF-4

RM-2.0

BUSHNELL ST

- November 2019 – City Council accepted donation from Devou Good Project for improvements to portion of Maryland Avenue – known as “Incline Run”
- Price Hill Will requests a Notwithstanding Ordinance (NWO) to further enhance this area
 - Installation of a 702 sq. ft. mural
 - Installation of a pair of sculpture arches

Existing Retaining Wall



Examples of Mural



Proposed Sculpture Arches

Bike Arch North Entrance Mockup:

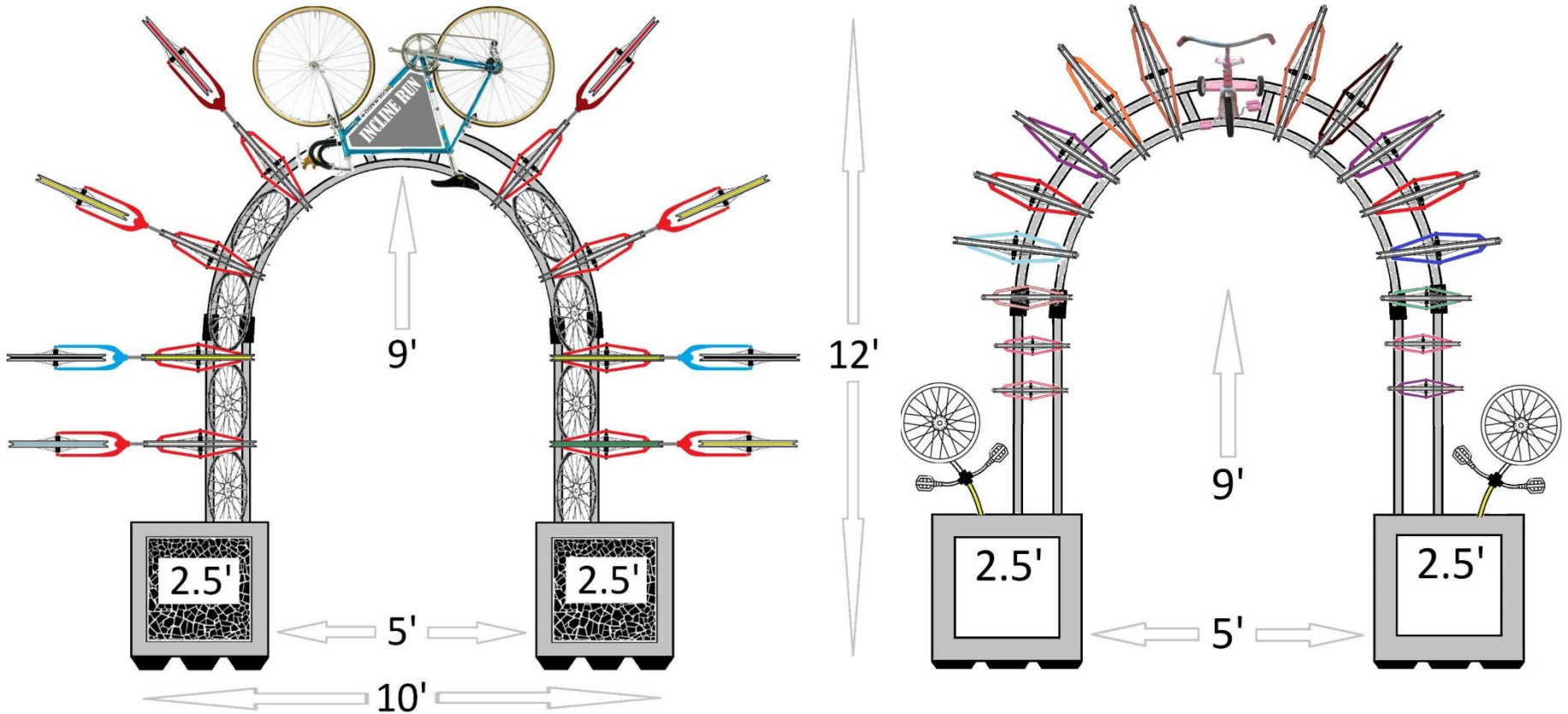



2.5''

2.5''

SF-4

PLANEAL

UNNAMED AL

RM-0.7

PRICE AV

MT HOPEAV

TATSON PL

PD

SF-2

MARYLAND AV

AW AV

WILL

INWAY AV

RMX

NEVADA ST

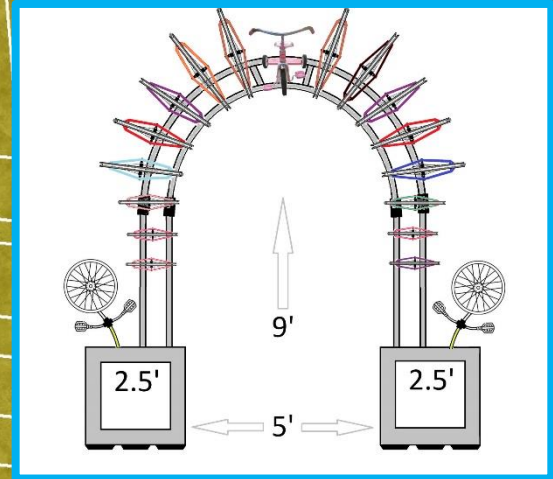
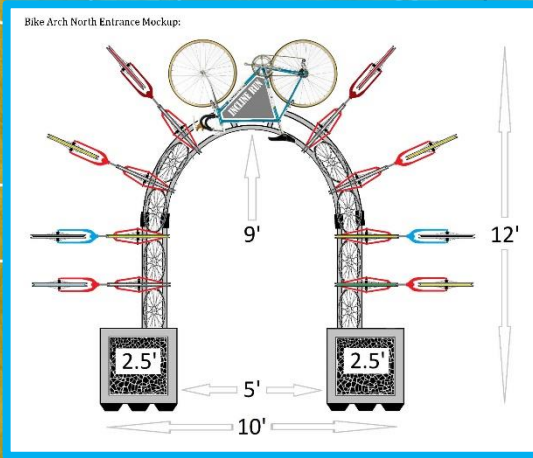

RM-2.0

BUSHNELL ST

Cincinnati Municipal Code – Sec. 111-5

- Whether the proposed application will not have an adverse effect on the character of the area or the public health, safety and welfare;
- Whether the proposed application is consistent with the purposes of this code and the zoning district where the subject property is located including but not limited to:
 - (see staff report for details)

Price Hill Plan (2015)

Arts and Culture Theme Area

Goal: Price Hill is an arts destination

Action Step: Support community art...in Lower, East, and West Price Hill.

Transportation Theme Area

Goal: Price Hill develops into a place that is attractive to residents and customers who want to travel without the use of a vehicle

Action Step: Develop the former site of the incline into a pedestrian connection

Plan Cincinnati (2012)

Connect Initiative Area

Goal: Develop an efficient multi-modal transportation system that supports neighborhood vitality

Strategy: Expand options for non-automotive travel

Live Initiative Area

Goal: Create a more livable community

Strategy: Become more walkable

- The mural installation celebrates the history of the Price Hill Incline and the sculpture arches instill the pedestrian environment of Maryland Avenue
- Consistent with *Plan Cincinnati* (2012) and the *Price Hill Plan* (2015)
- Notice was sent to all adjacent property owners and the Lower Price Hill and East Price Hill Community Councils on October 10, 2020
- One letter has been received to date – adjacent property owner

The City Planning Commission unanimously recommends that City Council approve the requested Notwithstanding Ordinance permitting the installation of a mural and artwork in City-owned right-of-way along a portion of Maryland Avenue with the following conditions included:

1. That the City-owned right-of-way of Maryland Avenue where the mural and sculpture installations are proposed is not a vehicular use right-of-way and is to be used as a pedestrian right-of-way providing access between Lower Price Hill and East Price Hill; and
2. That the mural and sculpture installations be placed in specific locations as listed by the applicant in Exhibit B and as reviewed and approved by the appropriate City departments; and

3. That the mural and sculpture installation designs adhere to the example illustrations as provided by the applicant in Exhibit B; and
4. The petitioner shall coordinate with the City regarding the donation of the mural and sculpture arches in the right of way including a contract with the City in a similar form as the City of Cincinnati Artwork Donation Agreement (Exhibit C); and
5. All artists involved in the creation and installation of the artwork shall provide the City with a Waiver of Rights pursuant to the Visual Artists Rights Act (Exhibit D).